



AUTOMATIC CHAIN TENSIONING.

The topping saw features an auto chain tensioning system that increases production and extends bar and chain life while minimizing service and maintenance. A chain removal tool is provided for safe and easy chain removal plus a manual tensioning device guarantees uptime.



CENTRAL GREASE BANK.

A recessed central grease bank delivers an easy point of service for most of the service points of the delimiting saw. The grease bank can be detached to service the remote grease lines and is on the same side as the grease point for the nose roller reducing service time.



CRADLE BEARING ROLLER ADJUSTMENT.

Easy roller adjustment allows quick changes to reduce stress on the cradle bearing and delay bearing bolt stretch. The roller track is made of AR400 steel to ensure a smooth rolling surface and allows the roller to be the wear point of the system to ensure long life and level movement of the delimiting saw.



GROUND LEVEL BAR OIL.

Ground level bar oil fill is another way Weiler keeps the operator safe and away from the knives. An adjustable oiler pump is also accessible at ground level to ensure steadfast bar maintenance. All daily service points are accessible from the ground and there is no need to climb on the delimiting saw frame.



IMPROVED EFFICIENCY.

The extension off of the delimiting saw provides a larger landing area helping stems slide into the delimiting saw throat. Longer knife edges on the front knives enable cutting larger diameter limbs thus improving delimiting capability before hitting the knife support and tearing the limb. Additional clean-out holes aid in daily maintenance and repair.



OPTIONAL FRONT GUIDE TUBE.

An optional front guide tube assists keeping the stems aligned in the throat and ensures the topping saw will cut everything in the delimiting saw. The front guide tube is best suited for first and second pine thinning. Many hardwood customers prefer to leave the tube off for improved delimiting and eliminating stems getting hung up in tube.

426A SPECIFICATIONS

| | | | | | |
|-----------------------------|------------------|---------------------------|--------------|---------------------------|---------------|
| THROAT OPENING | 35" 89 cm | SAW CHAIN | 3/4 pitch | TURNTABLE DIAMETER | 22" 56 cm |
| NOSE ROLLER DIAMETER | 16" 41 cm | SAW CHAIN LENGTH | 68 links | TRANSPORT WIDTH | 89.25" 2.27 m |
| SAW BAR LENGTH | 44" 112 cm | SAW CHAIN SPROCKET | 9 tooth | TRANSPORT HEIGHT | 97.75" 2.48 m |
| WEIGHT | 7,500 lb 3402 kg | OIL RESERVOIR | 8.2 gal 31 L | TRANSPORT LENGTH | 84.25" 2.14 m |

HYDRAULICS

- Ground level bar and chain oil reservoir
- Adjustable bar and chain oiler
- Automatic chain tensioner with manual tensioning override
- Independent knife flow control valves
- Hydraulic accumulator for knife floating

STANDARD EQUIPMENT

- Four knives (three movable and one fixed)
- Push / pull cutting edges
- Knife lockout pins
- Recessed central grease bank
- Easily adjustable bearing rollers
- Large rotating bearing
- Protected bump isolators

PRODUCT ENHANCEMENTS

- Larger landing area on right hand side for easier loading.
- Increased knife length edges for larger limb delimiting.
- Reduced knife angle to prevent slabbing.
- Longer saw bar and 68 link chain for increased topping saw capability.
- Rubber bumper overload protectors added for increased bumper life.
- Bottom swing bearing hose guard added for better hose protection.
- Angled cradle hose shield improvement to prevent damage.
- Pin driver holes added with weld on covers for easier service.
- Knife lockout pins standard for increased safety while performing repairs.
- Removed lip on top of saw box to reduce stem breakage.
- Plate added between front bed knife and saw box for less hang ups.
- Removable grease zerk bank for improved grease line service.

OPTIONAL EQUIPMENT

- Front Guide Tube
- No Topping Saw

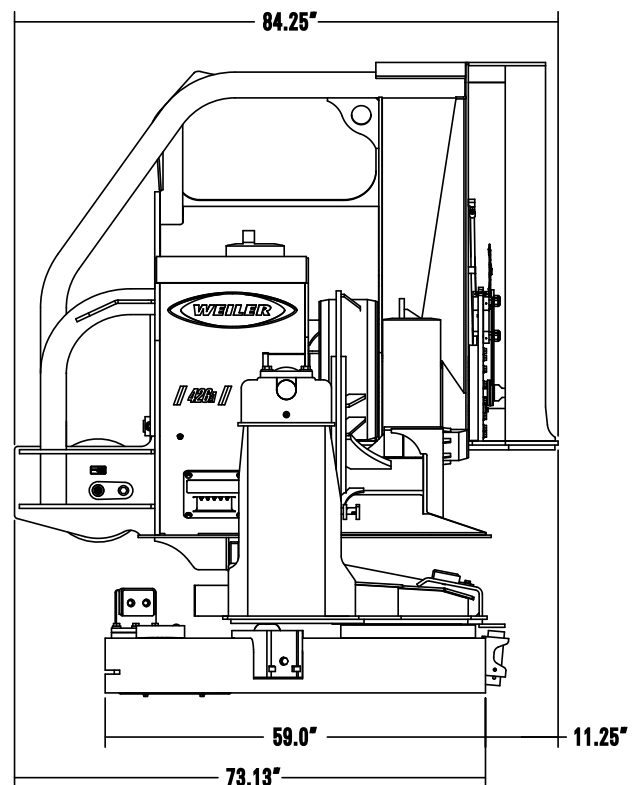
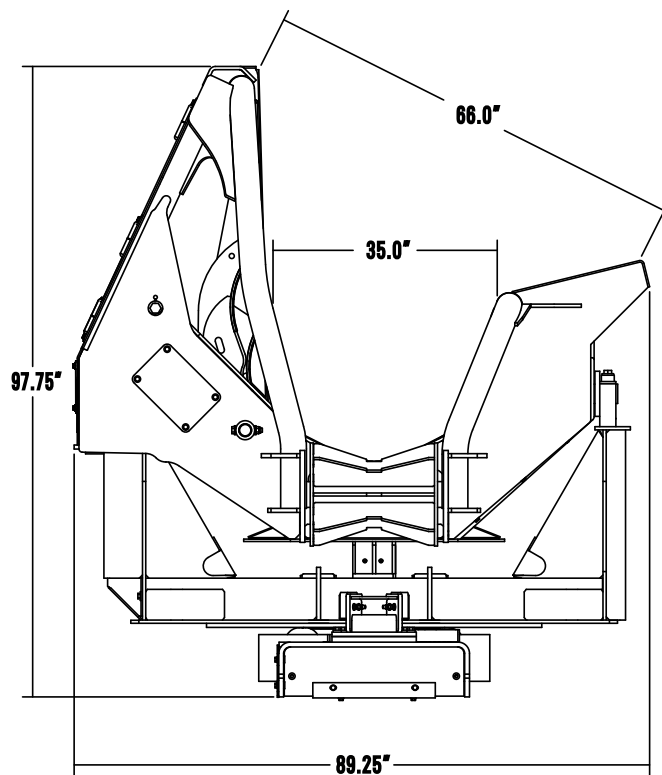

SALES AND SERVICE

Sold and serviced exclusively through Weiler Forestry dealers worldwide.

WARRANTY

12 months standard. Extended warranty available when purchased with a knuckleboom loader package.

